

# Magnetic Scale MXS2

## Manual



## Liability and Copyright

This manual and everything described in it are copyrighted. You may not copy this manual, in whole or part.

We reserve the right to change the manual/product without notice. In no event will WayCon be liable for direct, special, incidental, or consequential damage resulting from any defect in the product or its documentation, even if advised of the possibility of such damages.

## Contact

WayCon Positionsmesstechnik GmbH  
Siemensstr. 5  
85521 Ottobrunn  
Germany  
Phone: +49 89 679713 0  
Email: [sales@waycon.de](mailto:sales@waycon.de)  
Internet: [www.waycon.biz](http://www.waycon.biz)

# Content

1. Safety.....	5
1.1 General safety.....	5
1.2 Electrical safety.....	5
1.3 Mechanical safety.....	5
2. Mounting instructions.....	6
2.1 Dimensions.....	6
2.2 Magnetic Tape.....	6
2.3 Mounting the sensor.....	6
3. Electrical connection.....	8
3.1 GND connection.....	8
4. SSI interface.....	8
4.1 SSI (Synchronous Serial Interface).....	8
4.2 "MSB left aligned" protocol.....	9
4.3 Recommended transmission rates.....	10
4.4 Error bit.....	10
4.5 Helpful information.....	10
4.6 Recommended SSI input circuit.....	11
5. BiSS C-mode interface.....	12
5.1 Communication.....	12
5.2 Single Cycle Data.....	12
5.2.1 Position.....	12
5.2.2 Error.....	13
5.2.3 Warning.....	13
5.2.4 CRC.....	13
5.3 Control Data CD.....	14
5.3.1 Register address.....	14
5.3.2 RW.....	14
5.3.3 DATA.....	14
5.3.4 CRC.....	14
5.4 Used registers.....	15
5.4.1 Profile ID.....	15
5.4.2 Serial number.....	15
5.4.3 Command.....	16
5.4.4 Configuration.....	16
5.4.5 Absolute resolution.....	17
5.4.6 Preset / Offset.....	17
5.4.7 Device type.....	18
5.4.8 SINE / COSINE resolution.....	18

5.4.9 Position control .....	19
5.5 Application note.....	19
5.6 Recommended BiSS input circuit .....	19
6. AB incremental output signals.....	20
6.1 Recommended input circuit.....	21
7. Error and fault diagnostics.....	21
8. Maintenance.....	22
9. Troubleshooting .....	22
10. Default parameters list.....	23

# 1. Safety

## 1.1 General safety

- Installation and maintenance operations must be carried out by qualified personnel only, with power supply disconnected and stopped mechanical parts.
- The device must be used for the purpose appropriate to its design only. The use for purposes other than those for which it has been designed could result in serious personal or environmental damage.
- High current, voltage and moving mechanical parts can cause serious or fatal injury.
- Do not use in explosive or flammable areas.
- Failure to comply with these precautions or with specific warnings elsewhere in this manual violates safety standards of design, manufacture and intended use of the device.
- WayCon assumes no liability for the customer's failure to comply with these requirements.

## 1.2 Electrical safety

- Turn OFF the power supply before connecting the device.
- The electrical connection of the sensor must be carried out according to the explanation in section [3. Electrical connection](#).
- Unused wires must be cut to different lengths and insulated separately.
- In compliance with the norm 2004/108/EC on electromagnetic compatibility, the following precautions must be taken:
  - Before handling and installing the equipment, discharge electrostatic charges from your body and tools which may come in touch with the sensor.
  - Power supply must be stabilized without electrical noise. Install EMC filters on device power supply if needed.
  - Always use shielded cables.
  - Avoid cables that are longer than necessary.
  - Avoid running the connection cable near high voltage power cables.
  - Avoid installing the sensor near sources of capacitive or inductive noise. Shield the sensor from those noise sources if necessary.
  - To ensure a correct working of the sensor, avoid using strong magnets on or near the measurement system.
- Do not stretch the cable. Do not pull or carry the sensor by the cable. Do not use the cable as a handle.

## 1.3 Mechanical safety

- Install the device following strictly the information in section [2. Mounting instructions](#).
- Mechanical installation must be carried out by stopped mechanical parts.
- Do not open the housing of the sensor.
- Delicate electronic equipment! Handle with care! Do not subject the sensor to knocks or shocks.
- Protect the sensor against acidic solutions or chemicals that may damage it.
- Make sure, that the sensor and the magnetic tape are not jammed by chips, fillings or turnings.

## 2. Mounting instructions

### 2.1 Dimensions

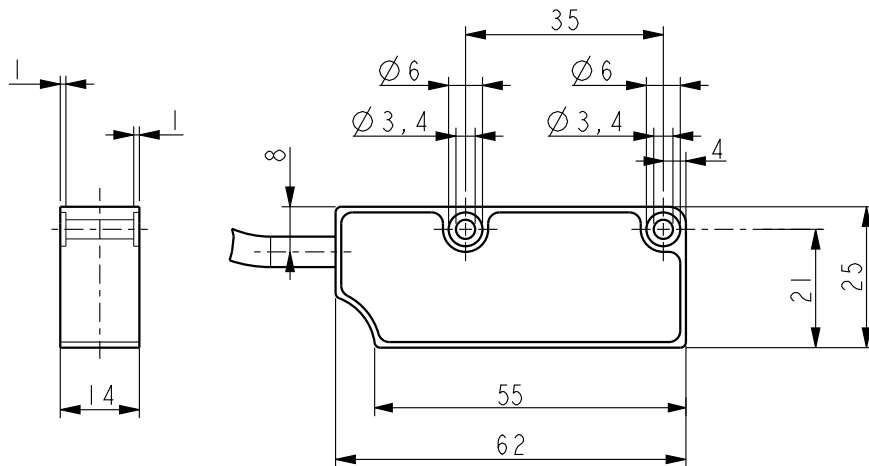

### 2.2 Magnetic Tape

Only pair the sensor with magnetic tape WBA2. For detailed information on the WBA2 magnetic tape and how to mount it please refer to its [installation guide](#).

The figures 1 and 2 shows how the sensor and the tape must be installed. Please note that the WBA2 magnetic tape is fitted with two tracks: an absolute track on one side and an incremental track on the other side. Thus, you must strictly comply with the mounting direction as indicated by the arrow on the tape!

### 2.3 Mounting the sensor

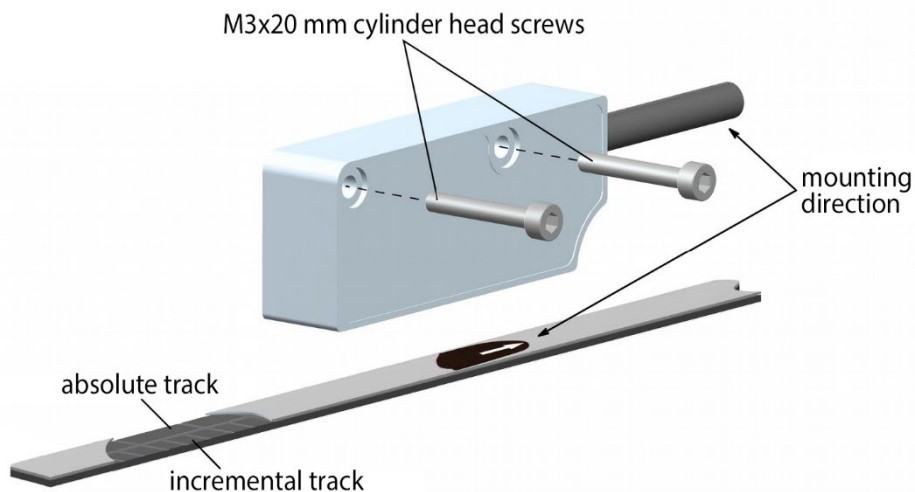
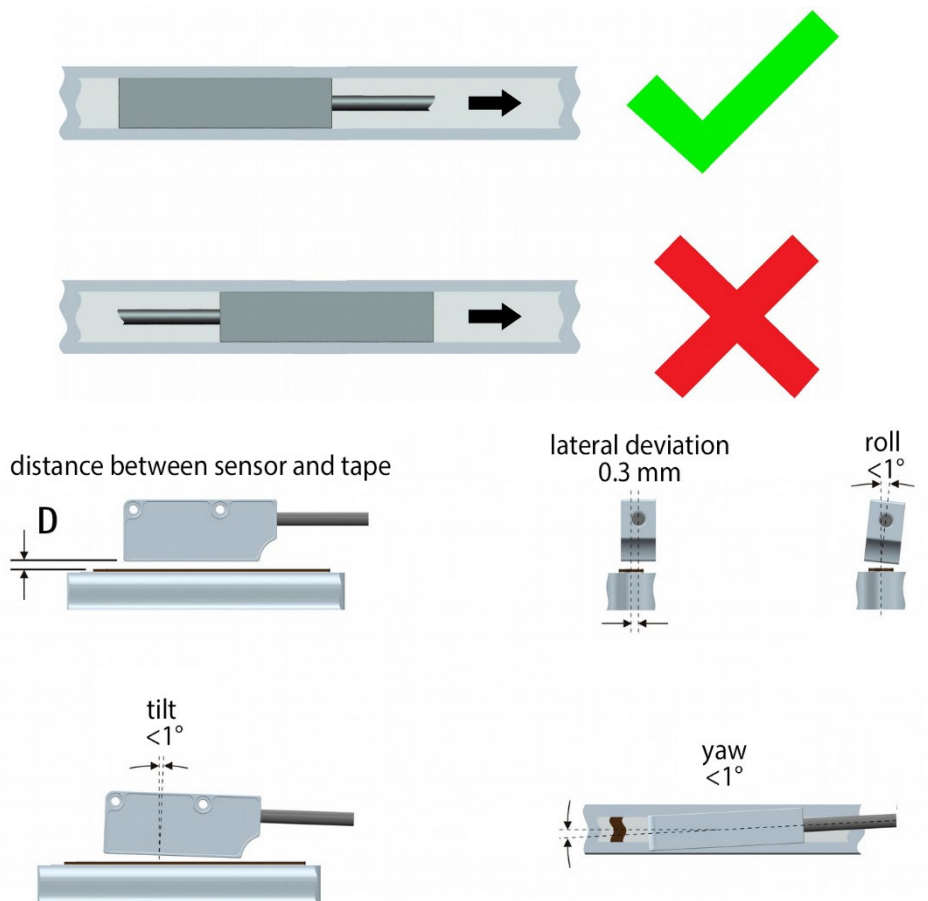

Figure 1

Make sure that the installation meets the system's mounting tolerances shown in the figures 1 and 2 along the whole measurement length. The system cannot work if the mounting direction is not abided!

Avoid contact between the sensor and the tape. Fix the sensor with two M3x20 mm cylinder head screws (recommended tightening torque: 1.1 Nm). The recommended minimum bend radius of the cable is  $\geq 42$  mm.



**Figure 2**

Please note that the WBA2 magnetic tape can be equipped with a stainless-steel cover strip (provided in delivery) to protect its magnetic surface. Therefore, the distance between sensor and tape is different whether the cover strip is applied or not.

The following table shows the range within which the distance between sensor and magnetic tape must be:

<b>Distance (D) between sensor and magnetic tape...</b>	
<b>...without cover strip</b>	<b>...with cover strip</b>
0.1...0.6 mm	0.1...0.4 mm

After the installation of the sensor and the magnetic tape a zero-setting / Preset operation is required. The zero-setting / Preset operation is further required every time either the sensor or the tape is replaced. This operation is only available for sensors with BiSS interface. It is not available for the SSI interface.

### 3. Electrical connection

Signal	Pins	Cable colour
GND	1	BK
+V	2	RD
Clock IN + / MA +	3	YE
Clock IN - / MA -	4	BU
Data OUT + / SLO +	5	GN
Data OUT - / SLO -	6	OG
A <sup>1)</sup>	7	WH
B <sup>1)</sup>	8	GY
Shield	Housing	Shield

Connector output M12, male

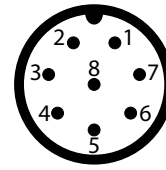

<sup>1)</sup> incremental signals A and B are only provided in versions SSII and BISS (see order code in the [data sheet](#))

#### Cable specifications

Model	HI-FLEX cable
Wires	6 x 0.14 mm <sup>2</sup> + 2 x 0.22 mm <sup>2</sup>
Shield	Tinned copper braid
External diameter Ø	5.3...5.6 mm
Conductor resistance	<148 Ω/km (0.14 mm <sup>2</sup> ); <90 Ω/km (0.22 mm <sup>2</sup> )
Minimum bend radius	Ø x 7.5 mm

#### 3.1 GND connection

Minimize electronic noise by connecting the shield and/or the connector housing and/or the sensor to GND. Make sure that GND is not affected by electronic noise. The connection point to GND can be situated both on the device side and/or on user's side. The best solution to minimize the interference must be carried out by the user.

### 4. SSI interface

**Order codes:** SSIG, SSII and SSIB

#### 4.1 SSI (Synchronous Serial Interface)



SSI (the acronym for Synchronous Serial Interface) is a synchronous point-to-point serial interface engineered for unidirectional data transmission between one Master and one Slave. Developed in 1984, it is based on the RS-422 serial standard.

Its most peculiar feature is that data transmission is achieved by synchronizing both the Master and the Slave devices to a common clock signal generated by the controller. In this way the output information is clocked out at each controller's request. Furthermore, only two pairs of twisted wires are used for data and clock signals, thus a six-wire cable is required.

The main advantages in comparison with parallel or asynchronous data transmissions are:

- less conductors are required for transmission
- less electronic components
- possibility of insulating the circuits galvanically by means of optocouplers
- high data transmission frequency
- hardware interface independent from the resolution of the absolute sensor

Furthermore, the differential transmission increases the noise resistance and decreases the noise emissions. It allows multiplexing from several sensors and thus process controls are more reliable with simplified line design and easier data management.

Data transmission is carried out as follows:

At the first falling edge of the clock signal (1, the logic level changes from high to low) the absolute position value is stored while at the following rising edge (2) the transmission of data information begins starting from the MSB.

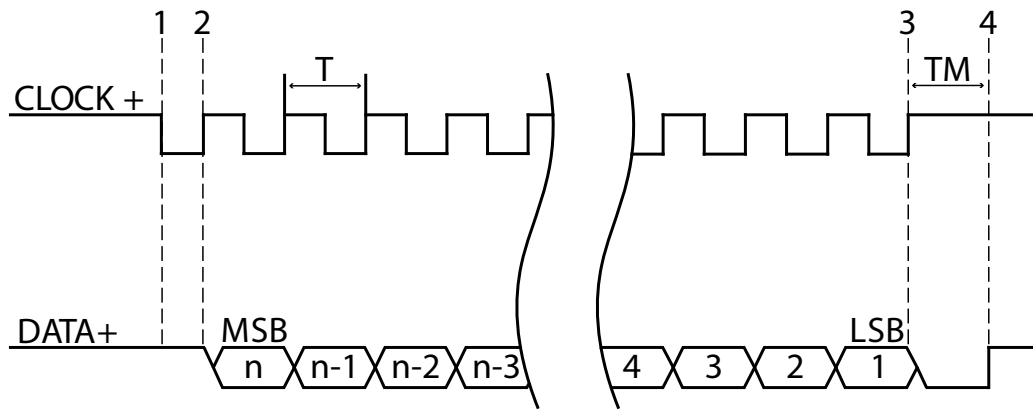

At each change of the clock signal and at each subsequent rising edge (2) one bit is clocked out at a time, up to LSB, so completing the data word transmission. The cycle ends at the last rising edge of the clock signal (3). This means that up to  $n + 1$  rising edges of the clock signal are required for each data word transmission (where  $n$  is the bit resolution). For instance, a 13-bit encoder needs 14 clock edges. If the number of clocks is greater than the number of bits of the data word, then the system will send a zero (low logic level signal) at each additional clock. Zeros will either lead (LSB ALIGNED protocol) or follow (MSB ALIGNED protocol) or lead and/or follow (TREE FORMAT protocol) the data word. After the period  $T_m$  monoflop time, having a typical duration of 12  $\mu$ s, calculated from the end of the clock signal transmission, the encoder is then ready for the next transmission and therefore the data signal is switched high.

The clock signal has a typical logic level of 5 V, the same as the output signal which has customarily a logic level of 5 V in compliance with RS-422 standard.

The output code can be either Binary or Gray (see order code in the [data sheet](#)).

## 4.2 “MSB left aligned” protocol

“MSB left aligned” protocol allows to left align the bits: beginning from MSB (most significant bit) to LSB (least significant bit), MSB is then sent at the first clock cycle. If the number of clock signals is higher than the data bits, then unused bits are forced to logic level low (0) and follow the data word. This protocol can be used in sensors having any resolution. The number of clocks to be sent to the sensor must at least equal the number of data bits. It can also be higher, as stated previously. The great advantage of this protocol over the TREE format or the LSB RIGHT ALIGNED format is that data can be transmitted with a minimum time loss and  $T_m$  monoflop time can immediately follow the data bits without any additional clock signal.

The device uses a variable number of bits to provide the position information, according to the resolution, as shown in the following table:

Resolution	Length of the word	Max. number of information
50 $\mu$ m	19 bits	18 bits (262143)
10 $\mu$ m	21 bits	20 bits (1048575)
5 $\mu$ m	22 bits	21 bits (2097151)
2 $\mu$ m	23 bits	22 bits (4194303)
1 $\mu$ m	24 bits	23 bits (8388607)

The output code can be either Binary or Gray (see order code in the [data sheet](#)).

The length of each information is equal to resolution.

Structure of position information:

MXS2-...-50-...	bit	19	...	2	1
MXS2-...-10-...	bit	21	...	2	1
MXS2-...-5-...	bit	22	...	2	1
MXS2-...-2-...	bit	23	...	2	1
MXS2-...-1-...	bit	24	...	2	1
	value	MSB	...	LSB	Error bit

**NOTE:** The position value issued by the sensor is expressed in pulses. To convert the pulses into a metric measuring unit, the number of detected pulses must be multiplied by the resolution.

Example:       MXS2-SSII-50-...  
                   resolution = 50 µm  
                   detected pulses = 123  
                   position value = 50 \* 123 = 6150 µm = 6.15 mm

### 4.3 Recommended transmission rates

The SSI interface has a frequency of data transmission ranging between 100 kHz and 1 MHz.

The CLOCK signal and DATA signal comply with the "EIA standard RS-422".

The SSI clock frequency (baud rate) depends on the length of the cable and must comply with the technical information reported in the following table:

Cable length	Baud rate
<50 m	<400 kHz
<100 m	<300 kHz
<200 m	<200 kHz
<400 m	<100 kHz

The time interval between two Clock sequence transmissions must be at least 16 µs ( $T_p > 16 \mu s$ ).

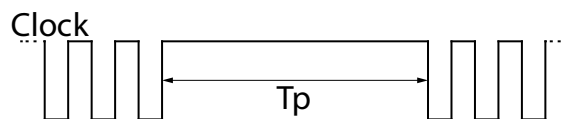

### 4.4 Error bit

The error bit is intended to communicate the normal or fault status of the Slave:

"1": correct status (no active error)

"0": an error is active:

- reading error:           The sensor is not reading the magnetic tape correctly. Among the possible causes are: the tape is not installed properly, the magnetic surface of the tape is damaged, the sensor is not working properly.
- frequency error:        The sensor is travelling too fast on the tape.

### 4.5 Helpful information

- The zero-setting / Preset and Counting direction functions are not available.
- The position information increases when the sensor moves as indicated by the arrow in figure 1, starting from a min. value up to a max. value. Min. and max. values depend on the specific WBA2 magnetic tape installed in your application.
- If required by your application, execute a zero-setting / Preset operation of the position read by the Master.

### 4.6 Recommended SSI input circuit

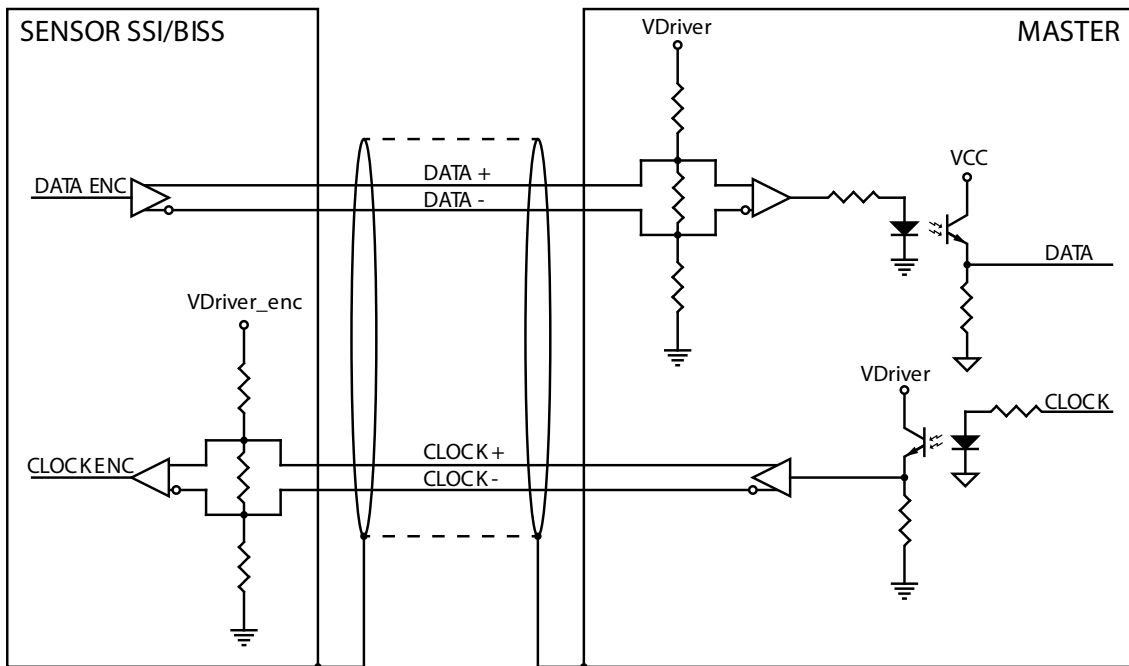

## 5. BiSS C-mode interface

**Order code:** BiSS

The MXS2 is a Slave device and complies with the “BiSS C-mode interface” and the “Standard encoder profile”. For detailed information not listed in this manual please refer to the official BiSS website ([www.biss-interface.com](http://www.biss-interface.com)).

The device is designed to operate in a point-to-point configuration and has to be installed in a “single Master – single Slave” network.

**ATTENTION:** Never connect the sensor in a “single Master – Multi Slave” network.

CLOCK MA and DATA SLO signal levels comply with the “RS-422 EIA standard”.

### 5.1 Communication

The BiSS C-mode protocol uses two types of data transmission protocols:

- **Single Cycle Data (SCD):** this is the primary data transmission protocol. It is used to transmit the process data from the Slave device to the Master device.
- **Control Data (CD):** transmission of a single bit following the SCD data. It is used to read data from or write data to registers of the Slave.

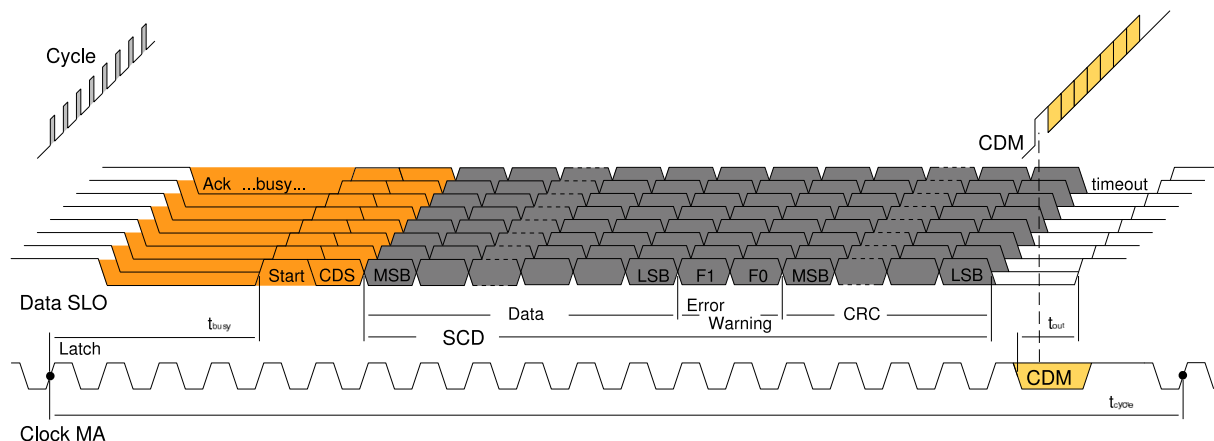

### 5.2 Single Cycle Data

SCD (32 bits) consists of the following values: 24-bit position value (Position), 1 error bit (Error, nE), 1 warning bit (Warning, nW) and CRC checking (CRC, 6 bits).

**SCD structure:**

bits	31...8	7	6	5...0
function	Position	Error	Warning	CRC

#### 5.2.1 Position

(24 bits)

Process data to be transmitted from Slave to Master.

The transmission starts with the MSB (most significant bit) and ends with the LSB (least significant bit).

bit	31...28	27	...	8
value	0000	MSB	...	LSB

To convert the position value into microns or millimetres, multiply the received data value by the resolution (see 4Dhex **Absolute resolution** register).

Example:       MXS2-BISS-50-...  
                  **absolute resolution** = 32 hex, 50 µm  
                  detected pulses = 123  
                  position value = 50 \* 123 = 6150 µm = 6.15 mm

### 5.2.2 Error

(1 bit)

This is intended to communicate the normal or fault status of the Slave.

nE = "1": correct status (no active error)  
      = "0": Error status: an error is active:

- Reading error:           The sensor is not reading the magnetic tape correctly. Among the possible causes are: the tape is not installed properly, the magnetic surface of the tape is damaged, the sensor is not working properly.
- Frequency error:        The sensor is travelling too fast on the tape.

### 5.2.3 Warning

(1 bit)

This is used along with the **Position control** register to perform an automatic position control.

**ATTENTION:** The use of both the **Position control** register and this **Warning** bit is strictly reserved to WayCon technicians.

### 5.2.4 CRC

(6 bits)

CRC (Cyclic Redundancy Check) is the error checking field resulting from a "Redundancy Check" calculation performed on the message contents. This is intended to check whether transmission has been performed properly (inverted output).

Polynomial:  $X^6+X^1+1$  (binary: 1000011)

**Logic circuit:**

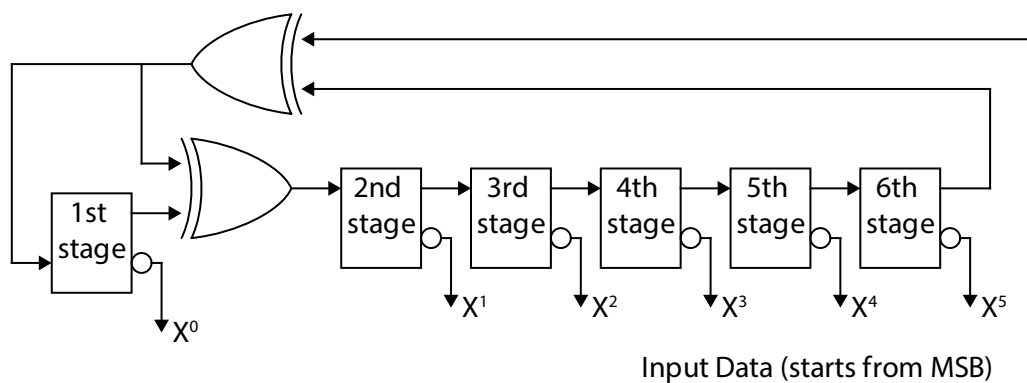

### 5.3 Control Data CD

For complete CD structure information please refer to the official BiSS documents: "Protocol description C-mode".

Main control data is described in the section below.

#### 5.3.1 Register address

(7 bits)

This is the address of the register. It specifies the register you need to read from or write to.

#### 5.3.2 RW

(2 bits)

It sets whether you need to write to register (**RW** = "01") or to read from the register (**RW** = "10").

**RW** = "01": when you need to write to the register

**RW** = "10": when you need to read from the register

#### 5.3.3 DATA

(8 bits)

When writing to register (**RW** = "01"): this is the value to be set in the register (i.e. transmitted from the Master to the Slave).

When reading from the register (**RW** = "10"): this is the value to be read in the register (i.e. transmitted from the Slave to the Master).

**Data bit structure:**

<b>bit</b>	<b>7</b>	<b>...</b>	<b>...</b>	<b>0</b>
	MSB	...	...	LSB

#### 5.3.4 CRC

(4 bits)

CRC (Cyclic Redundancy Check) is the error checking field resulting from a "Redundancy Check" calculation performed on the message contents. This is intended to check whether transmission has been performed properly (inverted output).

Polynomial:  $X^4+X^1+1$  (binary: 10011)

**Logic circuit:**

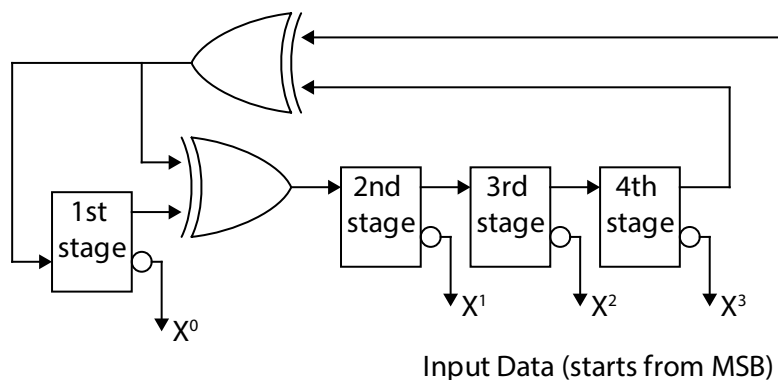

## 5.4 Used registers

Register (hex)	Function
42...43	<a href="#">Profile ID</a>
44...47	<a href="#">Serial number</a>
48	<a href="#">Command</a>
49	<a href="#">Configuration</a>
4D	<a href="#">Absolute resolution</a>
51...53	<a href="#">Preset / Offset</a>
55	<a href="#">Device type</a>
58	<a href="#">SINE / COSINE resolution</a>
59	<a href="#">Position control</a>

All registers in this section are listed according to the following scheme:

### Function name

#### [Address, access]

Description of the function and default value.

- Address: register address expressed in hexadecimal notation.
- Access:
  - ro = read only
  - rw = read and write
  - wo = write only
- Default parameter values are written in ***bold italics***.

### 5.4.1 Profile ID

#### [42...43, ro]

These registers contain the identification code of the used profile.

Register	42	43	
Hex	28	12	MXS2-BISS-50-...
		14	MXS2-BISS-10-...
		15	MXS2-BISS-5-...
		16	MXS2-BISS-2-...
		17	MXS2-BISS-1-...

See "Standard encoder profile", "data format", "Variant 0-24".

### 5.4.2 Serial number

#### [44...47, ro]

These registers show the serial number of the device expressed in hexadecimal notation.

- Register 44: year of production
- Register 45: week of production
- Registers 46 and 47: serial number in ascending order

### 5.4.3 Command

[48, wo]

Value	Function
00	Normal operation
01	Save parameters on EEPROM
02	Save and activate Preset / Offset
04	Load and save default parameters

After having set a new value in some register, use the **Save parameters on EEPROM** function in this register to store it. Set "01" in the register.

After having set a Preset / Offset value, use the **Save and activate Preset / Offset** function in this register to both store and activate the preset / offset at the same time. Set "02" in the register.

**Load and save default parameters:** default parameters are set to allow the operator to run the device for standard operation in a safe mode. As soon as the command is sent the default parameters are uploaded and activated. All parameters which have been set previously are overwritten, thus previously set values are lost. The complete list of machine data and the relevant default parameters preset by WayCon are available at the [last page](#) of this manual. Set "04" in the register.

**ATTENTION:** As soon as the **Load and save default parameters** command is sent, all parameters which have been set previously are overwritten, thus previously set values are lost!

As soon as the command is sent, the register is set back to "00" (**Normal operation**) automatically.

Wait min. 30 ms (EPROM writing time) before using a new function.

Default = 00 (**Normal operation**)

### 5.4.4 Configuration

[49, rw]

Bit	Function	bit = 0	bit = 1
0	Not used	-	
1	Set preset / offset	<b>Preset</b>	Offset
2	Enable preset / offset	<b>Enable</b>	Disable
3	Not used	-	
4	Not used	-	
5	Output code	Gray	<b>Binary</b>
6	Counting direction *	<b>Standard</b>	Inverted
7	Not used	-	

\* it affects the absolute position information, not the AB incremental signals

#### Set preset / offset

This parameter is available only if the **Enable preset / offset** parameter is set to ENABLE. It allows to activate either the preset function (**Set preset / offset** = PRESET) or the offset function (**Set preset / offset** = OFFSET); the Preset or Offset value has to be set in the Preset / Offset register. After having enabled the preset / offset functions (**Enable preset / offset** = ENABLE), this item allows to activate either the preset function or the offset function. The value set in the Preset / Offset register will have a different meaning depending on the value of this parameter whether it is set to PRESET (0) or OFFSET (1). In the first case (**Set preset / offset** = PRESET) the Preset / Offset register is used to set the preset value; while in the second case (**Set preset / offset** = OFFSET) the Preset / Offset register is used to set the offset value. To activate the preset / offset value use the Save and activate Preset / Offset function in the Command register (set "02" in the register 48). For any information on the preset and offset functions refer to the Preset / Offset register on [page 17](#).

Default = 0 (**Preset**)

### Enable preset / offset

It enables / disables the preset / offset functions. After having enabled the use of the functions you have to choose whether to activate the preset or the offset in the **Set preset / offset** parameter. Then to activate a new value, set it next to the Preset / Offset register and send the **Save and activate Preset / Offset** command (set "02" in the register 48).

Default = 0 (*enable*)

### Output code

The sensor provides the absolute position information in the desired code format: GRAY (0) or BINARY (1).

Default = 1 (*Binary*)

### Counting direction

The **standard counting direction** is to be intended with sensor moving as indicated by the arrow in Figure 1. This parameter allows to reverse the counting direction. In other words, it allows the count up when the sensor moves in the reverse of the standard direction, i.e. in the opposite direction to the one shown by the arrow in Figure 1. It is possible to choose the following options: STANDARD (0) and INVERTED (1). When the counting direction is set to STANDARD, the position information increases when the sensor moves according to the arrow in Figure 1. When the option INVERTED is set, the position information increases when the sensor moves in reverse of the standard direction, i.e. in the opposite direction to the one shown by the arrow in Figure 1.

Default = 0 (Standard)

**NOTE:** The **Counting direction** parameter affects the absolute position information, not the AB incremental signals.

The new setting will be active immediately after transmission. Use the **Save parameters on EEPROM** function (set "01" in the register 48) to store the new value.

Configuration register default value = **20h**

## 5.4.5 Absolute resolution

[4D, ro]

It allows to read the resolution of the absolute sensor.

32hex:	Resolution = 50 µm	(max position = 03 FF FFh, 18 bits)
0Ahex:	Resolution = 10 µm	(max position = 0F FF FFh, 20 bits)
05hex:	Resolution = 5 µm	(max position = 1F FF FFh, 21 bits)
02hex:	Resolution = 2 µm	(max position = 3F FF FFh, 22 bits)
01hex:	Resolution = 1 µm	(max position = 7F FF FFh, 23 bits)

## 5.4.6 Preset / Offset

[51...53, rw]

This function is available only if the **Enable preset / offset** parameter in the Configuration register is set to ENABLE. Furthermore, it has a double function depending on whether the **Set preset / offset** parameter in the Configuration register is set to PRESET or OFFSET. In the first case (**Set preset / offset** = PRESET) the Preset / Offset register is used to set the preset value. In the second case (**Set preset / offset** = OFFSET) the Preset / Offset register is used to set the offset value.

**ATTENTION:** Activate the preset / offset value only when the device is not moving.

### Preset

The Preset function is meant to assign a value to a desired physical position of the sensor. The chosen physical position will get the value set next to this item and all the previous and following positions will get a value according to it. This function is useful, for example, when the zero position of the sensor and the zero position of the axis need to match. The preset value will be set for the position of the sensor in the moment when the preset value is activated. To activate the preset, stop the sensor in the desired position, enter the desired value next to this Preset / Offset register and then send the **Save and activate Preset / Offset** command in the Command register (set "02" in the register 48).

### Offset

The offset function is meant to assign a value to a desired physical position of the sensor so that the output position information is shifted according to the value next to this Preset / Offset register. The number of transmitted values will match the max number of position information as per the set resolution, but the output information will range between the Preset / Offset value (minimum value) and the sum of the max. position information as per the set resolution (see the Absolute resolution register) + the Preset / Offset value (maximum value). The offset value will be set for the position of the sensor in the moment when the offset value is activated. To activate the offset, stop the sensor to the desired position, enter the desired value next to this Preset / Offset register and then send the **Save and activate Preset / Offset** command in the Command register (set "02" in the register 48).

### Preset / Offset structure:

Register	51	52	53
	MSB	...	LSB
	$2^{23} \dots 2^{16}$	$2^{15} \dots 2^8$	$2^7 \dots 2^0$

Use the **Save and activate Preset / Offset** function (set "02" in the register 48) to store and activate the new value.

The max. allowed Preset value depends on the set resolution:

resolution = 50 $\mu\text{m}$	max preset = 03 FF FFh (18 bits)
resolution = 10 $\mu\text{m}$	max preset = 0F FF FFh (20 bits)
resolution = 5 $\mu\text{m}$	max preset = 1F FF FFh (21 bits)
resolution = 2 $\mu\text{m}$	max preset = 3F FF FFh (22 bits)
resolution = 1 $\mu\text{m}$	max preset = 7F FF FFh (23 bits)

The Offset value must be less than or equal to the difference between the overall position information (24 bits, see **Position**) and the max. position information allowed by the set resolution (see the **Absolute resolution** register).

Default = **00h**

## 5.4.7 Device type

[55, ro]

This register describes the type of device.

Default = **07h**: BiSS linear encoder + AB incremental signal

## 5.4.8 SINE / COSINE resolution

[58, ro]

This register describes the period of the sine/cosine signal.

Default = **00h**: the register is not used

### 5.4.9 Position control

[59, rw]

This is used along with the **Warning** bit (see on [page 13](#)) to perform an automatic position control.

Default = **00h**

**ATTENTION:** Do not change the value in this register, its use is strictly reserved to WayCon technicians.

### 5.5 Application note

Device communication specifications:

Parameter	Value
Clock Frequency	Min. 200 kHz, max. 10 MHz
BiSS Timeout	Auto adaptation to clock, max. 16 $\mu$ s
Internal position update frequency	30 kHz

### 5.6 Recommended BiSS input circuit

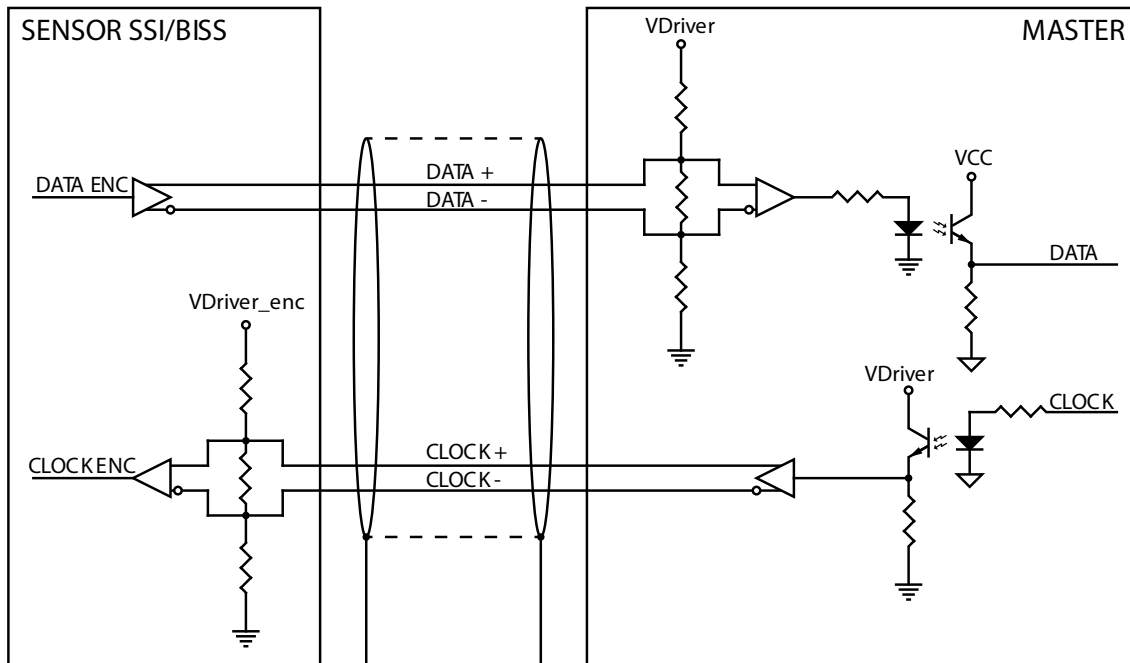

## 6. AB incremental output signals

**Order code:** SSII and BISS

In addition to the absolute position information, MXS2 sensors can provide AB incremental signals through the NPN open collector output circuit. They require +5 VDC  $\pm 5\%$  power supply with  $I_{out} = 40$  mA max. Thermal and short-circuit protections are not provided.

Please note that the WBA2 magnetic tape is fitted with two tracks: an absolute track on one side and an incremental track on the other side. Thus, you must strictly comply with the mounting direction! For complete information refer to section [2. Mounting instructions](#) and to section [3. Electrical connection](#).

In the following table the main features of the incremental measuring system are listed for each order code (see [data sheet](#)). They concern the resolution (i.e. the distance between two following edges of A and B channels), the minimum edge distance (i.e. the minimum spacing between two following signal edges at output), the maximum counting frequency and the maximum travel speed.

Order code	Resolution	Min. edge distance *	Max. AB frequency	Max. travel speed
MXS2-...-50-...	50 $\mu\text{m}$	0.25 $\mu\text{s}$	73 kHz	7 m/s
MXS2-...-10-...	10 $\mu\text{m}$	0.25 $\mu\text{s}$	350 kHz	7 m/s
MXS2-...-5-...	5 $\mu\text{m}$	0.25 $\mu\text{s}$	580 kHz	7 m/s
MXS2-...-2-...	2 $\mu\text{m}$	0.25 $\mu\text{s}$	580 kHz	2.8 m/s
MXS2-...-1-...	1 $\mu\text{m}$	0.25 $\mu\text{s}$	580 kHz	1.4 m/s

\* max. counting frequency = 4 MHz

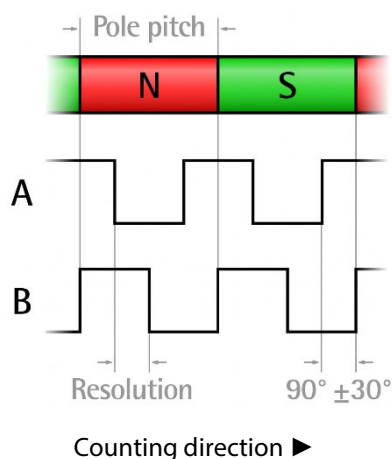

Please note that the incremental signals and their relationship with the pole pitch are represented schematically in the Figure above. In the example the interpolation factor 4 is used. The real interpolation factor results from the size (expressed in  $\mu\text{m}$ ) of the pole pitch divided by the resolution of the specific sensor.

Example:       MXS2-SSII-50-...  
                   Resolution = 50  $\mu\text{m}$   
                   Pole pitch size = 2000  $\mu\text{m}$

$$\text{Interpolation factor} = \frac{2000}{50} = 40$$

Thus, in the case of the MXS2-SSII-50-... sensor, the system will provide 40 AB pulses per each pole.

**NOTE:** Please note that the **Counting direction** parameter available in the BiSS-C interface (see on [page 17](#)) affects the absolute position information, not the AB incremental signals.

## 6.1 Recommended input circuit

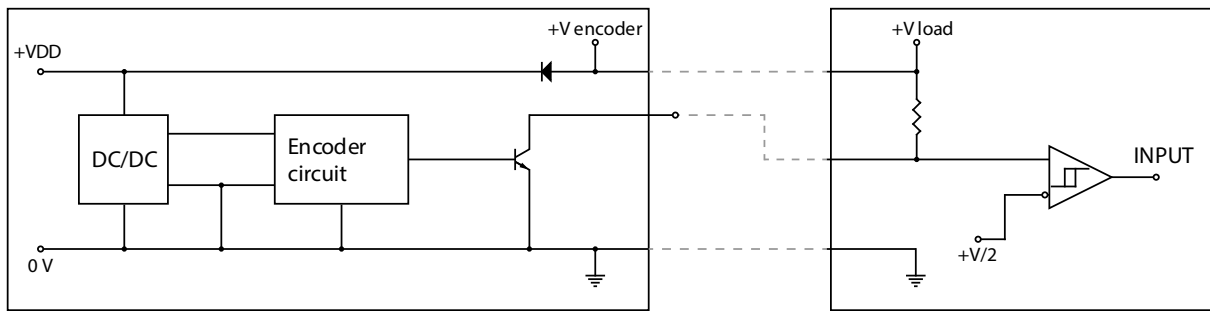

+V encoder = +5 VDC  $\pm$ 5%

+V load = +5 VDC  $\pm$ 5% typically

$I_{out}$  = 40 mA max.

Max. cable length = 10 m

The max. frequency allowed for the AB signals depends on the cable length and the applied load.

Thermal and short-circuit protections are not provided.

## 7. Error and fault diagnostics

In case of wrong alignment between the sensor and the magnetic tape, at power on or during operation the following errors may occur:

- When switching on the system an alarm is triggered through the dedicated bit: the tape is not read correctly. This may be due to one of the following reasons: the tape is not mounted properly; the tape's magnetic surface is damaged somewhere; the sensor is not working properly causing invalid data to be transmitted.  
As soon as the sensor is aligned correctly the error bit switches to high logic level.
- During operation an alarm is triggered through the dedicated bit: as previously stated, the tape is not read correctly. This may be due to one of the reasons listed above.  
Furthermore, the alarm may be caused by a frequency error: the sensor is travelling too fast on the tape. The last valid position is "frozen" (kept in memory) until the next valid position is detected on the tape.

In the SSI interface, the device status is transmitted via the error bit, see section [4.4 Error bit](#).

In the BiSS interface, the device status is transmitted via the nE bit, see section [5.2.2 Error](#).

**NOTE:** When the error bit has high logic level (normal status, no alarm active), this means that the sensor is working properly and both the absolute position information and the incremental signals are output correctly. Please note that the error bit is intended to communicate the status of both the absolute interface and the AB incremental signals.

## 8. Maintenance

The magnetic measurement system does not need any particular maintenance. It should be handled with utmost care as any delicate electronic equipment. From time to time we recommend the following operations:

- Periodically check the soundness of the structure and make sure that there are no loose screws. Tighten them if necessary.
- Check the mounting tolerances between the sensor and the magnetic tape. They must be met all along the whole measuring length. Mechanical movement may compromise the correct operation. Wear of the machine may increase the tolerances.
- The surface of the magnetic tape has to be regularly cleaned using a soft and clean cloth to remove dust, chips, moisture etc.

## 9. Troubleshooting

The following list shows some typical faults that may occur during installation and operation of the magnetic measurement system.

### Fault:

The system does not work (no pulse output).

### Possible cause:

- The tape and/or the sensor are not installed properly. The active surface of the tape does not match the sensitive part of the sensor or the sensor's installation does not comply with the mounting direction. For correct installation please refer to section [2. Mounting instructions](#).
- A magnetic component or a protective surface is interposed between the sensor and the tape. Only non-magnetic materials are allowed between the sensor and the tape.
- Installation does not meet the mounting tolerances between the sensor and the tape indicated in this manual. During operation the sensor hits the surface of the tape (check whether the sensor sensitive part is damaged). Or the sensor is mounted too far from the tape.
- The sensor has been damaged by short circuit or wrong connection.

### Fault:

The measured values are either inaccurate or not provided in the whole length.

### Possible cause:

- The mounting tolerances between the sensor and the tape are not met all along the whole measuring length. For correct installation see section [2. Mounting instructions](#).
- The sensor is not installed properly on the tape.
- The connection cable runs near high voltage cables or the shield is not connected properly.
- Frequency error: the sensor is travelling too fast on the tape.
- The frequency of the Master clock is set too high or too low and the transmission cannot be synchronized correctly (see sections [4. SSI interface](#) and [5. BiSS C-mode interface](#)).
- A section of the magnetic tape has been damaged mechanically or magnetically along the measuring length.
- The measuring error is caused by a torsion in the machine structure. Check parallelism and symmetry in the movement of the machine.

## 10. Default parameters list

BISS-C interface

Parameter	Default value *
Command	00
Configuration	20
Bit 0 - not used	0
Bit 1 - Set preset / offset	0 = Preset
Bit 2 - Enable preset / offset	0 = Enable
Bit 3 - not used	0
Bit 4 - not used	0
Bit 5 - Output code	1 = Binary
Bit 6 - Counting direction	0 = Standard
Bit 7 - not used	0
Preset / Offset	00 00 00

\* all values are expressed in hexadecimal notation.