

MAGNETIC SCALE

Links to further documents for this series:

[Installation guide sensor](#)

[Installation guide magnetic tape](#)



MXAZ SERIES

Key-Features:

- Cost effective non-contacting absolute encoder
- Measurement ranges up to 1250 mm
- Linearity up to <math><0.5\%</math>
- Teachable resolution
- Analog output: 4...20 mA, 0...10 V
- Protection class IP68
- Operating temperature range from -25°C to +85°C
- Self-diagnostics on tape distance & integrity

Content

Technical Data Sensor MXAZ.....	2
Technical Data Magnetic Tape WBAZ	2
Technical Drawing	3
Electrical Connection.....	3
Order Code Sensor.....	4
Order Code Magnetic Tape.....	4
Accessories.....	4

TECHNICAL DATA SENSOR MXAZ

Measurement range	[mm]	max. 1250 (magnetic tape length -80 mm)
Linearity max.	[%]	<0.5
Repeatability		±1 increment
Resolution		teachable
Position refresh	[µs]	100
Output		4...20 mA, 0...10 V
Supply	[VDC]	13...30
Power consumption	[W]	max. 1
Connection		Hi-flex cable with open wires or cable with connector M12, 8 pins
Protection class		IP68 (IP69K on request)
Operating temperature	[°C]	-25...+85
Storage temperature	[°C]	-40...+100
Shock resistance		250 g, 6 ms according to CEI EN 60068-2-27
Vibration resistance		10 g, 5...2000 Hz according to CEI EN 60068-2-6
EMC		according to EN 61000-6-2 level 3
Gap between sensor and tape	[mm]	0.1...2
Travel speed (mechanical)	[m/s]	max. 5
Function		Teach-in of output range
Housing		Macromelt OM 646-EN

TECHNICAL DATA MAGNETIC TAPE WBAZ

Length	[mm]	max. 1330
Accuracy class	[µm/m]	±35
Polar pitch	[mm]	2
Protection class		IP67
Operating temperature	[°C]	-25...+85
Storage temperature	[°C]	-40...+100
Thermal expansion coefficient	[1/K]	0.000016

CHEMICAL RESISTANCE MAGNETIC TAPE WBAZ

Acetone	••	Kerosene	•	Seawater	••
Acetylene	••	Ketone	•••	Steam heat	•
Antifreeze (Glacial acetic acid)	•	Mineral / Motor oil	•	Thinner	•••
Benzene	•••	Petrol	••	Turpentine	••
Heptane	•••				

• No effect or low effect •• Low to Medium effect ••• Strong effect

TECHNICAL DRAWING

Sensor MXAZ

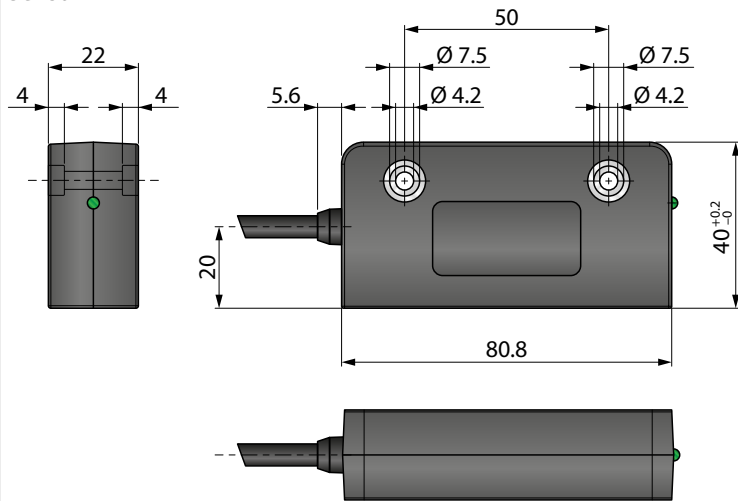

Diagnostic LED

ON	The sensor is running properly, there are no active errors
Blinking at high frequency (100 ms ON / 100 ms OFF)	Machine data parameters error
Blinking slowly (500 ms ON / 500 ms OFF)	Flash memory error
Blinking very slowly (1 s ON / 1 s OFF)	Error of the sensors while reading the magnetic tape
Single flash (200 ms ON / 1 s OFF)	The sensor is installed too far from the magnetic tape, the installation does not comply with the tolerance values between the sensor and the tape
Double flash (200 ms ON twice / 1 s OFF)	Several errors are active in the same time

Magnetic tape WBAZ

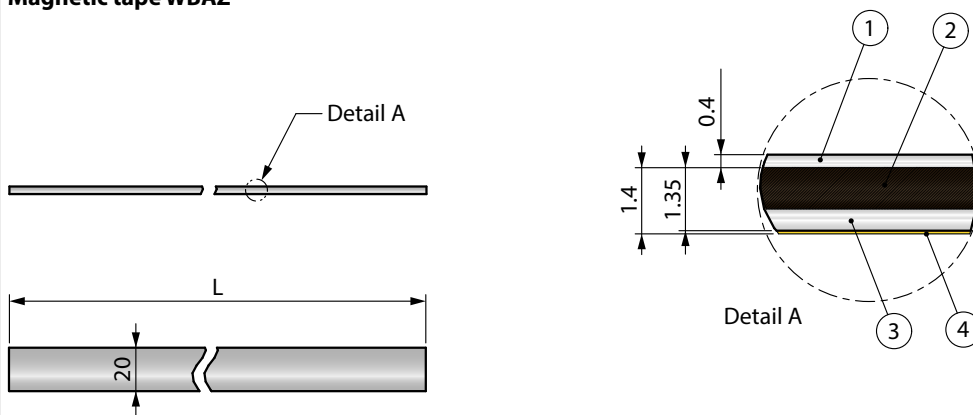

1	Stainless steel protective strip
2	Plastoferrite tape
3	Base tape
4	Adhesive tape
L	Magnetic tape length

ELECTRICAL CONNECTION

Function	Cable output	Connector output	Connection cable K8P...
GND _{Supply}	BK	Pin 1	WH
+V	RD	Pin 2	BN
GND _{Signal}	YE	Pin 3	GN
START	BU	Pin 4	YE
Signal	GN	Pin 5	GY
STOP	OG	Pin 6	PK
n. c.	WH	Pin 7	BU
FAULT ¹⁾	GY	Pin 8	RD
Shield	Shield	Housing	Shield

¹⁾ only available with output option AI1

Connector, M12 (male)

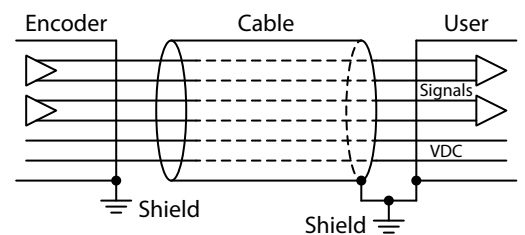
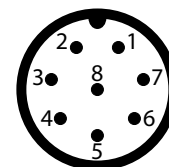

ORDER CODE SENSOR

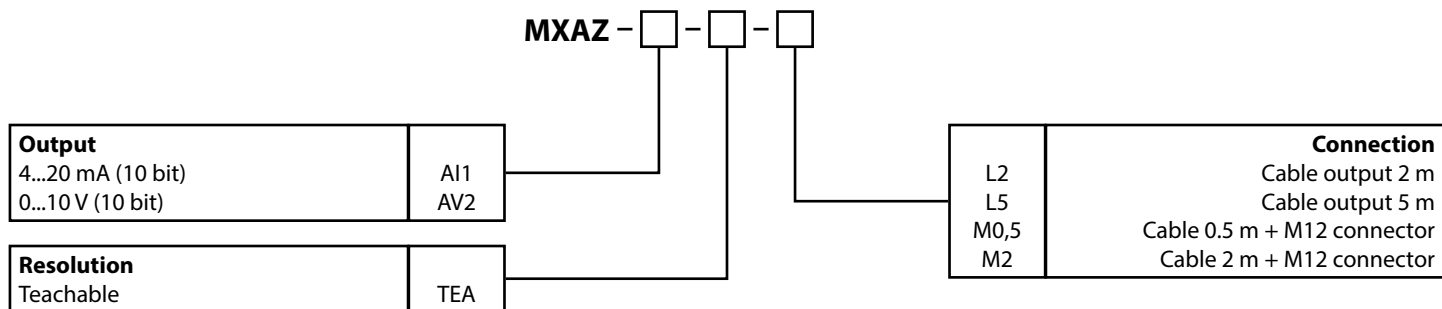

ORDER CODE MAGNETIC TAPE

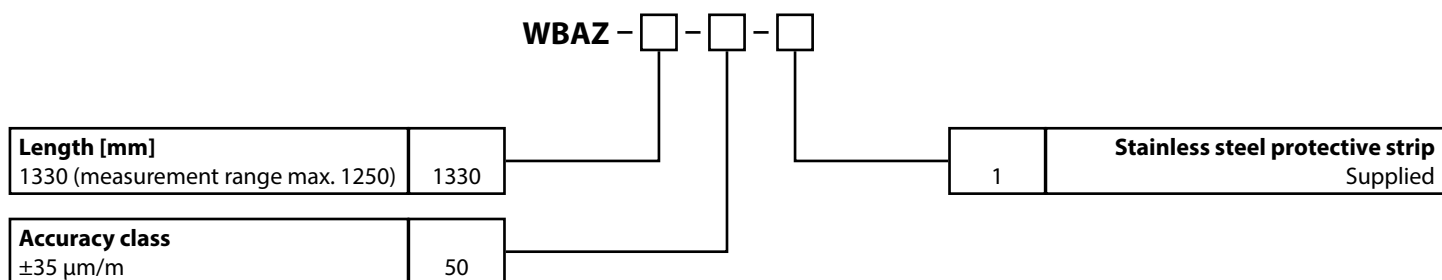

ACCESSORIES

Cable with connector (female) M12, 8 poles, shielded, IP67

K8P2M-S-M12	2 m, straight connector
K8P5M-S-M12	5 m, straight connector
K8P10M-S-M12	10 m, straight connector

Mating connector (female) M12, 8 poles, for self assembly

D8-G-M12-S	straight connector
D8-W-M12-S	angular connector

Digital displays for sensors with analog output, 2 channel

WAY-AX-S	touch screen, supply: 18...30 VDC
WAY-AX-AC	touch screen, supply: 115...230 VAC

For more information and options please refer to the [WAY-AX data sheet](#).

Subject to change without prior notice.

WayCon Positionsmesstechnik GmbH

Email: info@waycon.de
Internet: www.waycon.biz

WayCon
Positionsmesstechnik

Headquarters Munich

Siemensstr. 5
85521 Ottobrunn
Tel. +49 (0)89 67 97 13-0

Office Cologne

Auf der Pehle 1
50321 Brühl
Tel. +49 (0)89 67 97 13-100