

# INSTALLATION GUIDE

## Magnetic Scale Series MXAX and MXAZ

For more information please see the data sheet at [www.waycon.biz/products/magnetic-scales/](http://www.waycon.biz/products/magnetic-scales/)

### FIRST STEPS

WayCon Positionsmesstechnik GmbH would like to thank you for the trust you have placed in us and our products. This manual will make you familiar with the installation and operation of our magnetic scale sensors. Please read this manual carefully before initial operation!

Unpacking and checking:

Carefully lift the device out of the box by grabbing the housing. After unpacking the device, check it for any visible damage as a result of rough handling during the shipment. Check the delivery for completeness.

If necessary consult the transportation company, or contact WayCon directly for further assistance.

### SAFETY

- Installation and maintenance have to be carried out by qualified personnel only.
- During installation and maintenance make sure that the machine is not running and the power supply is OFF.
- The encoder must be used only for the purpose appropriate to its design. The use for purposes other than those for which it has been designed could result in serious personal and/or environment damages.
- High current, voltage and moving mechanical parts can cause serious or fatal injury.
- Warning! Do not use in explosive or flammable areas.
- Failure to comply with these precautions or with specific warnings elsewhere in this manual violates safety standards of design, manufacture and intended use of the equipment.
- WayCon assumes no liability for the customer's failure to comply with these requirements.

### MECHANICAL SAFETY

- For the installation of the device strictly follow the information in the section "Mounting the sensor".
- Mechanical installation has to be carried out only when the machine is switched off.
- Do not disassemble the device, do not tool the device.
- Protect the unit against acid solutions or chemicals that may damage it.
- Sensitive electronic equipment: handle with care. Do not shock or drop the device.
- During installation we suggest protecting the device against pollution, like chips, filings or liquids. Should this be impossible, please make sure that adequate cleaning measures (as for instance brushes, scrapers, jets of compressed air, etc.) are in place in order to prevent the sensor and the magnetic scale from jamming.

# MOUNTING THE SENSOR

- Fix the sensor by means of two M4x25 mm cylinder head screws.
- Always comply with the mounting tolerances indicated in the figures below.
- Use the WBAX type magnetic scale for the MXAX reading head or the WBAZ for the MXAZ reading head (refer to specific technical instructions). The arrow indicates the standard counting direction (count up information).
- Recommended minimum bend radius of the cable:  $R \geq 25$  mm.

## Overall dimensions

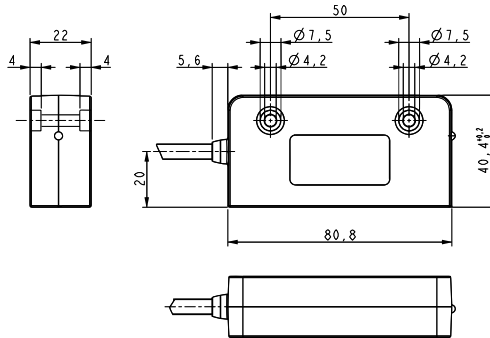

## Mounting direction

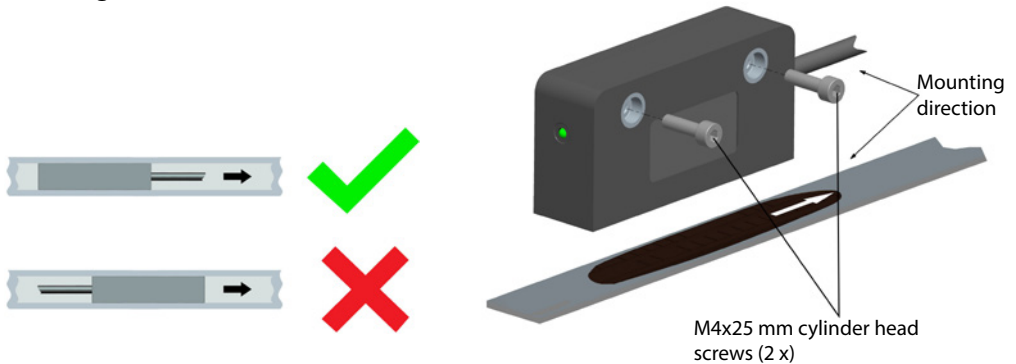

## Recommended mounting tolerances

Distance from the scale

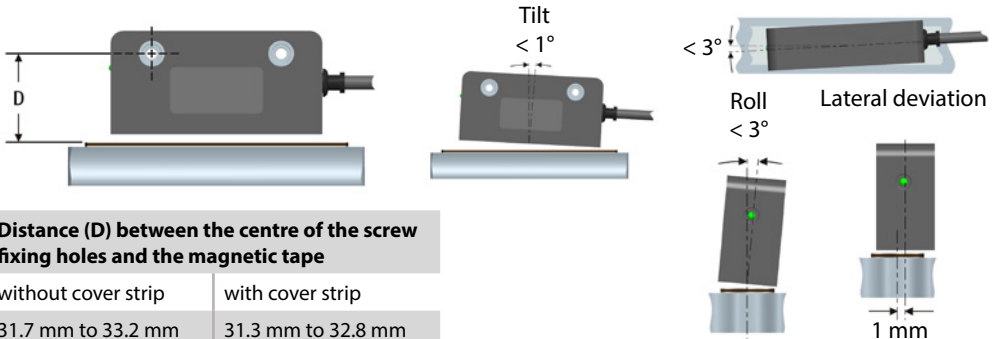

# ELECTRICAL SAFETY

- Turn OFF the power supply before connecting the device.
- Unconnected wires must be cut at different lengths and insulated singularly.
- Do not stretch the cable. Do not pull or carry by cable. Do not use the cable as a handle.
- In compliance with 2004/108/EC norm on electromagnetic compatibility, following precautions must be taken:
  - Before handling and installing the equipment, discharge electrostatic charges from your body and tools which may come in touch with the device.
  - Power supply must be stabilized without electronic noise. Install EMC filters on device power supply if needed.
  - Always use shielded cables (twisted pair cables whenever possible) and avoid cables longer than necessary.
  - Avoid placing the signal cable near high voltage power cables.
  - Mount the device as far as possible from any capacitive or inductive noise source. Shield the device from electronic noise source if needed.
  - To guarantee a correct working of the device, avoid using strong magnets on or near by the unit.
  - Minimize electronic noise by connecting the cable shield and/or the connector housing and/or the sensor to ground. Make sure that ground is not affected by electronic noise.

# ELECTRICAL CONNECTION

Signals 0...20 mA		Signals 0...10 V	cable output	connector output	K8PXM-S-M12 <sup>1)</sup> cable colours
0 VDC Power Supply			BK	1	WH
13...30 VDC			RD	2	BN
0 VDC analog			YE	3	GN
START			BU	4	YE
+I out	+V out		GN	5	GY
STOP			OG	6	PK
not connected			WH	7	BU
FAULT	not connected		GY	8	RD
Shielding			Shield	Case	Shield

<sup>1)</sup> Accessory cable. X = cable length in m

## Cable specifications

Type	HI-FLEX M8
Wires	2 x 0.22 mm <sup>2</sup> + 6 x 0.14 mm <sup>2</sup>
Shield	Tinned copper braid
External Ø	5.3 up to 5.6 mm
Impedance	<90 Ω/Km (0.22 mm <sup>2</sup> ), <148 Ω/Km (0.14 mm <sup>2</sup> )
Min. bend radius	≥25 mm

connector output,  
M12, male

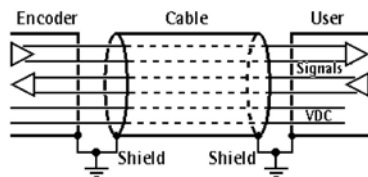

## ELECTRICAL CONNECTION

### Connection of the shield

For signal transmission always use shielded cables. The cable shielding must be connected properly to the metal ring nut of the connector in order to ensure a good earthing through the frame of the device.

### Ground connection

Minimize electronic noise by connecting the shield and/or the connector housing and/or the sensor to ground. Make sure that ground is not affected by electronic noise. The connection point to ground can be situated both on the device side and/or on user's side. The best solution to minimize the interference must be carried out by the user.

## SIGNAL DESCRIPTION

### 0 VDC

0 VDC Power Supply and 0 VDC analog are internally connected.

### START input

START input is used to execute the TEACH-IN procedure. It is active at HIGH logic level (voltage greater than 10 V must be applied). For any further information on using the START and STOP inputs please refer to the "TEACH-IN procedure" section.

### +I out current analog output

+I out provides the current analog signal. AI1 output range is: min. quote = 4 mA, max. quote = 20 mA. The increment at each step is as follows: 10-bit DAC      4...20 mA:  $16000/1024 = 15.625 \mu\text{A}$

### +V out voltage analog output

+V out provides the voltage analog signal. AV2 output range is: min. quote = 0 V, max. quote = 10 V. The increment at each step is as follows: 10-bit DAC      0...10 V:  $10000/1024 = 9.765 \text{ mV}$

### STOP input

STOP input is used to execute the TEACH-IN procedure. It is active at HIGH logic level (voltage greater than 10 V must be applied). For any further information on using the START and STOP inputs please refer to the "TEACH-IN procedure" section.

### Fault output

This Fault output is only available for AI1 current analog output. It is intended to show an error condition such as a circuit break.

Please pay attention to the value of the R2 resistor.

$$I_{\text{max}} = 50 \text{ mA} \quad R1 = 47 \Omega \quad R2 = (VDC/I) - R1$$

No encoder error = transistor ON (conducting)

Encoder error = transistor OFF (open)

## TEACH-IN PROCEDURE

The TEACH-IN function allows to set a start and end position by means of two external signals. The analog signal will automatically adapted to the teached range.

The set output range (the overall information to be output) is defined over the travel of the specific application and is comprised between the ends of the axis: the origin of the axis, i.e. the point where you activate either the START or the STOP input, and the end of the axis, i.e. the point where you activate the other input. For the positions beyond the travel limits the current / voltage signal level will be kept at the minimum / maximum value of the selected range.

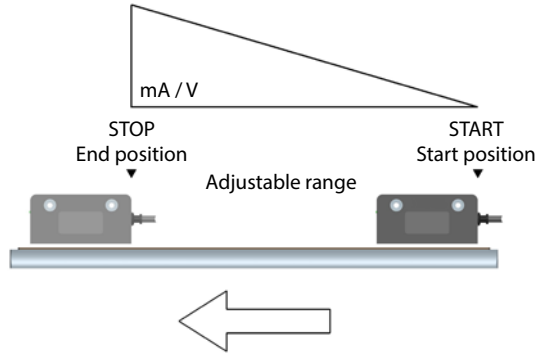

With ascending ramp, before the initial position of the travel the encoder will provide the minimum current / voltage signal level of the output range (4 mA for AI1; 0 V for AV2). After the last position of the travel the encoder will provide the maximum current / voltage signal level of the output range (20 mA for AI1; 10 V for AV2).

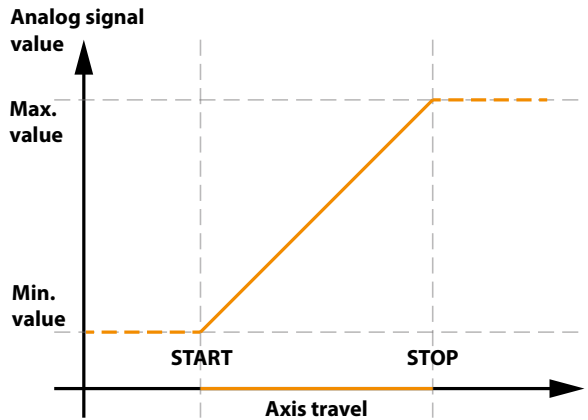

On the contrary, with descending ramp, before the initial position of the travel the encoder will provide the maximum current / voltage signal level of the output range (20 mA for AI1; 10 V for AV2). After the last position of the travel the encoder will provide the minimum current / voltage signal level of the output range (4 mA for AI1; 0 V for AV2).

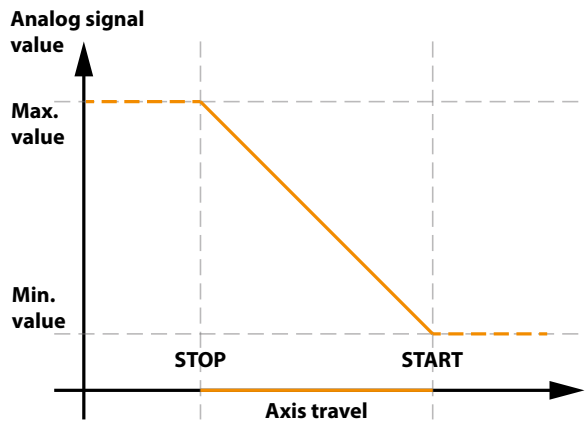

**WARNING:** It is mandatory to activate the START input first and then the STOP input.

## TEACH-IN PROCEDURE

To programme the encoder using the TEACH-IN procedure act as described below. The following steps define a ramp with increasing output values:

- Move the axis to the origin of the physical travel of the application you want to measure and control. In other words, move it to the point where the travel starts.
- Switch the START input to HIGH logic level +VDC for 3 seconds at least; the LED in the sensor switches off. This way you set the point where the encoder will provide the minimum current / voltage signal level available in the output range (4 mA for AI1; 0 V for AV2).
- Now move the axis to the end of the physical travel of the application you want to measure and control. In other words, move it to the point where the travel stops.
- Switch the STOP input to HIGH logic level +VDC for 3 seconds at least; the LED in the sensor switches on again. This way you set the point where the encoder will provide the maximum current / voltage signal level available in the output range (20 mA for AI1; 10 V for AV2).

For a descending ramp (as shown in the figure on the previous page) activate the START input and then move backward the axis in reverse of the standard direction before activating the STOP input (in other words you activate the START input when the axis is in the final position of its travel and then activate the STOP input when the axis is in the first position of its travel). The maximum value of the output range precedes the initial point of the ramp (i.e. the beginning of the axis travel). The minimum value of the output range follows the final point of the ramp (i.e. the end limit of the axis travel).

**WARNING:** If you set a wrong point for the initial position of the travel by activating the START input, you have to turn off and then on again the power supply to reset the sensor. Then repeat the procedure from the first step.

Otherwise, if you set a wrong point for the final position of the travel by activating the STOP input (this means that you have already set the initial position of the travel by activating the START input), you have to switch the STOP input to 0 VDC. Then move the axis to the right final position and activate the STOP input.

## RECOMMENDED CIRCUIT

### Current output

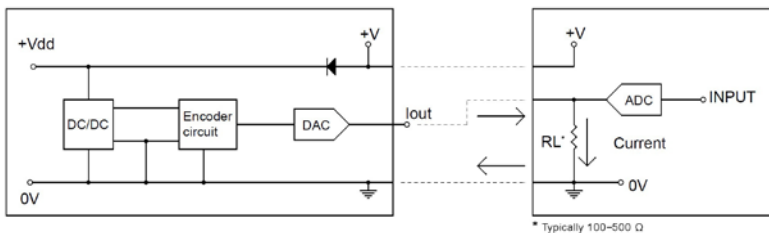

### Voltage output

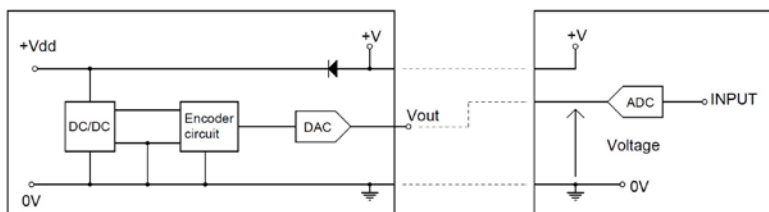

## MAINTENANCE

The magnetic measurement system does not need any particular maintenance. Please always consider it is a sensitive electronic equipment and therefore it must be handled with care. From time to time we recommend the following operations:

- Periodically check the proper assembly of the sensor system and make sure that there are no loose screws, tighten them if necessary.
- Check the mounting tolerances between the sensor and the magnetic scale all along the measuring length. Wear of the machine may increase the tolerances.
- The surface of the magnetic scale should be cleaned periodically by using a soft cloth to remove dust, chips, moisture etc.

## TROUBLESHOOTING

The following list shows some typical faults that may occur during installation and operation of the magnetic measurement system.

**Fault:** The system does not work (no pulse output).

**Possible cause:**

- The tape or the sensor has been mounted incorrectly (the active part of the tape does not match the active side of the sensor).
- A magnetic part or a protection surface is interposed between the sensor and the tape. Only non-magnetic materials are allowed between the sensor and the tape.
- Installation does not comply with the tolerance gap between the sensor and the scale indicated in this guide. The sensor hits the surface of the scale or is too far from it. Check whether the sensor sensitive part is damaged.
- The sensor has been damaged by a short circuit or a wrong connection.

**Fault:** The measured values are either inaccurate or not provided in the whole length.

**Possible cause:**

- The mounting tolerances between the sensor and the tape are not met all along the whole measurement length.
- The connection cable is located next to a high voltage cable. or the shielding is not connected correctly. Check the earthing point.
- A section of the magnetic scale has been damaged mechanically or magnetically along the measuring length.
- The measuring error is caused by torsion of the machine structure. Check parallelism and symmetry of machine movement.



## DIAGNOSTIC LED

### Diagnostic LED

ON	The sensor is running properly, there are no active errors
Blinking at high frequency (100 ms ON / 100 ms OFF)	Machine data parameters error
Blinking slowly (500 ms ON / 500 ms OFF)	Flash memory error
Blinking very slowly (1 s ON / 1 s OFF)	Error of the sensors while reading the magnetic tape
Single flash (200 ms ON / 1 s OFF)	The sensor is installed too far from the magnetic tape, the installation does not comply with the tolerance values between the sensor and the tape
Double flash (200 ms ON twice / 1 s OFF)	Several errors are active in the same time

**Note:** When you execute the TEACH-IN, as soon as you activate the START input the LED switches off. As soon as you activate the STOP input it switches on again.

## DECLARATION OF EC-CONFORMITY

WayCon Positionsmesstechnik GmbH  
Mehlbeerenstrasse 4  
82024 Taufkirchen / Germany

This is to certify that the products

Classification      Magnetic scales  
Series                MXAX and MXAZ  
fulfill the current request of the following EC-directives:  
EMV-directive      2014/30/EU  
                                 2011/65/EU  
applied harmonized standards:  
CEI EN 61000-6-4, CEI EN 61000-6-2

The declaration of conformity loses its validity if the product is misused or modified without proper authorisation.

Taufkirchen, 02.10.2017

  
Andreas Täger  
CEO